

LIMITED WARRANTY CERTIFICATE

THIS WARRANTY APPLIES TO THE ORIGINAL REGISTERED OWNER ONLY



APPLICABLE TERMS

All Caribe inflatable boats, parts, and accessories are warranted under conditions of normal handling and use for a period of one year from the date of purchase against structural defects in material and workmanship. Ordinary wear and tear shall not be considered a defect in workmanship or material.

In addition, from the date of purchase, the hypalon-neoprene fabric is warranted for a period of five years against flaws affecting the use of the boat (such as porosity, delamination and cracking) when employed under conditions of normal use. Stains, which in the majority of cases are the result of inadequate maintenance, do not affect the use of the boat and are therefore not covered under warranty. Caribe Nautica will repair, or, at their option, replace the boat affected by any of the flaws described above.

After the assessment of a warranty claim, Caribe Náutica may choose to replace a boat with the same model, if available or a comparable product. The warranted boat must be returned in a condition of normal wear and tear together with all its standard accessories. To the contrary, charges may be applied on the final claim agreement.

Application of the guarantee

To be able to apply the foreseen guarantee the page one of this manual must be completed with all details, with the stamp of the dealer and the possession of the original invoice.

NON-COVERAGE

This warranty does not cover:

- * Damages or defects caused by alterations to the product or any of its parts.
- * Repairs made or accessories installed by unauthorized service centers or repairmen.
- * Damages or defects caused by negligence, accidents, abuse, and improper usage of the product, its parts and accessories.
- * Engines and drives carry, the warranty as provided by the manufacturer of that particular accessory or equipment.
- * If is installed a bigger engine of the recommended one

CARIBE LIABILITY

Caribe's liability concerning any claim related to the sale or use of Caribe boats, parts, attachments and accessories is limited to the Caribe sale price of the boat or of the part to which that claim is related. Caribe shall not on any account be liable for incidental or consequential damages in connection with the use of Caribe boats, parts or accessories. Some states do not allow the exclusion or limitation of incidental or consequential damages. This warranty applies to the original owner only.

CLAIM PROCEDURE

All claims must be submitted within thirty days after occurrence of the problem. The owner must notify, in writing, the dealer from whom the boat was originally purchased. Photographs illustrating all damages together with the proof of purchase must be submitted to verify the claim. The dealer will then work together with Local Importer to analyze and resolve the warranty problem. If the owner is unable to contact the original dealer, he or she should notify the Local Importer and the owner will be advised how to proceed. All transportation costs related to a claim are at the owner's expense.

For all claims that require arbitration, it is understood that proceedings relevant to those claims will be conducted in the resident territory of the Local Importer.

OWNER'S MANUAL
DINGHIES LINE C8 • CBX • C9 • C9X • C10 • C10X
LIGHT LINE LB - L9 - L10 - L11
RUNABOUT LINE C12 - C12X - C13 - C14
ROWERS LINE C25 - C27 - C32 - I27 - I32

OWNER'S MANUAL
DL LINE DL11- DL12- DL13- DL15- DL17 • DL20-DL20S- DL25
CL LINE CL13- CL14
UB LINE UB12 B/SC- UB13 B/SC- UB15 B/SC- UB17 B/SC UB19 B/SC • UB20 B/SC- UB24 B/SC

BOAT MODEL: _____ CATEGORY: _____ TYPE OF CRAFT: INFLATABLE RIB

HIN No. VE-EMD | | | | | | | | | | | | INVOICE No. _____ DATE: / /

MANUFACTURER: CARIBE NAUTICA

ADDRESS: 1ª CALLE LA INDUSTRIA, EDF.CARIBE-CARACAS-VENEZUELA

EMAIL: CARIBENAUTICA1@HOTMAIL>COM

DISTRIBUTOR NAME: _____

ADDRESS: _____



"This manual has been compiled to help you to operate your craft with safety and pleasure. It contains details of the craft, the equipment supplied or fitted, its systems, and information on its operation and maintenance. Please read it carefully, and familiarize yourself with the craft before using it".

If this is your first craft, or you are changing to a type of craft you are not familiar with, for your own comfort and safety, please ensure that you obtain handling and operating experience before assuming command of the craft. Your dealer or national sailing federation or yacht club will be pleased to advise you of local sea schools, or competent instructors.

"PLEASE KEEP THIS MANUAL IN A SECURE PLACE, AND HAND IT OVER TO THE NEW OWNER WHEN YOU SELL THE CRAFT"

CONTENTS

- Information.....1
- Certification.....2
- Light Line.....3
- Dinghies Line.....4
- Accesories.....5
- Use and Performance.....6
- Towing - Lifting.....6
- Inflate and Maintenance.....7
- Runabout Line.....8
- CL Line.....9
- Internal Distribution.....10
- DL Line.....11,12,13
- UB Line.....14,15,16
- Rowers Line.....17
- Minor Repairs.....18

WARRANTY:

With this manual you will receive the guarantee certificate with the terms and conditions under which defects in your boat will be repaired. Please familiarize yourself with the warranty and follow the instructions regarding the proper operation and maintenance. Lack of attention to these instructions can void the warranty.

MINOR REPAIRS

MINOR REPAIRS

Each caribe boat is equipped with a repair kit for minor repairs or emergency, that consist of: a tube of glue, a set of patches and a piece of sandpaper

PROCEDURE:

- 1) Locate the leak by spraying soapy water and watching for air bubbles
- 2) Select the appropriate patch, present it against the puncture and mark with a pencil around the edge of the patch (do not use a pen) . (Fig. 1)
- 3) Put masking tape on the lines marked. (Fig. 2)
- 4) Sand the marked area and clean the dust. (Fig. 2)
- 5) Apply a thin and uniform layer of glue on the patch and on the marked area. Wait approximately 10 minutes for the glue to dry apply the glue again. (Fig. 3)
- 6) Let the glue dry again and stick the patch on the area that is being repaired. (Fig. 4)
- 7) In Order to take out the air trapped between the patch and the tube, rub the patch with a round object, such as a screw driver handle, rub from the center to the edge of the patch while applying a strong pressure, (Fig. 5)
- 8) Allow to dry for 48 hours.

Fig. 1

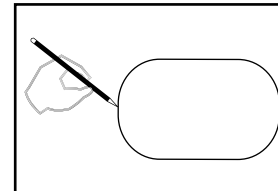

Fig. 2

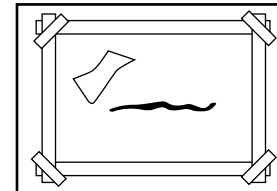

Fig. 3

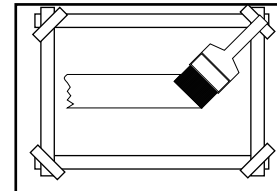

Fig. 4

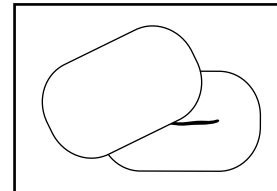
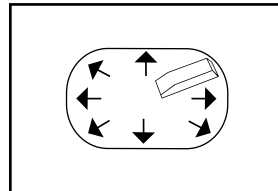

Fig. 5



For major repairs contact an authorized Caribe Dealer

ROWERS LINE

	C25	I27/C27	I32/C32
O.A(A) LENGTH	2,51mt 8'3"	2,86mt 9'1"	3,10mt 10'3"
O.A(B) BEAM	1,64mt 5'5"	1,64mt 5'5"	1,64mt 5'5"
MAX ENGINE	8 kw 10 HP	11 kw 15 HP	15 kw 20 HP
ENGINE SHAFT	SHORT (15")	SHORT (15")	SHORT (15")
MAX LOAD CAPACITY	448 KG 987 LBS	520 KG 1146 LBS	577 KG 1272 LBS
MAX N° PERSONS	4	4	4
APROX WEIGHT B.	42 KG 93 LBS	52 KG 115 LBS	58 KG 128 LBS
TUBE Ø	0,44	0,44	0,44

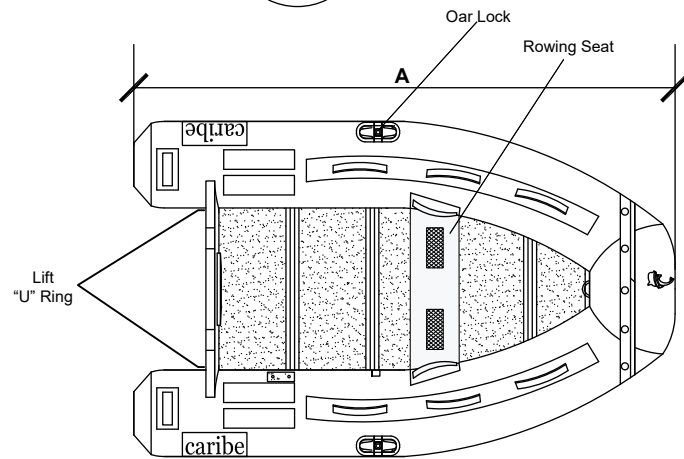
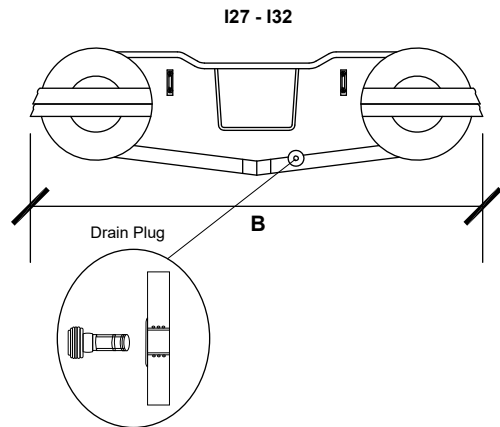
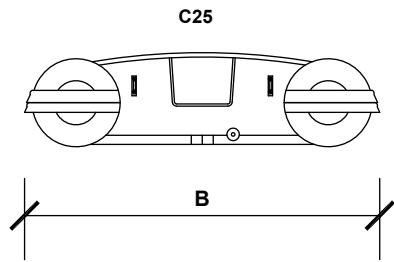

STANDARD ACCESORIES
2 OARS* FOOT PUMP* REPAIR KIT
ROWING SEAT* DOCUMENT POCKET

WARNING
Before launchig the boat, make sure that the drain plugs are secured into the valves

PREPARE YOUR BOAT:
Please follow these stepsto prepare your boat at navigate:
1) Inflate the tubes (page 7)
2) Installation of the oars (page 5)
3) Installation of the seat (page 5)
4) Placing the drain plug

CONFORMITY							
C8 - C8X	ISO-6185-3	CARIBE-003	RIB	C14-T14	ISO-6185-3	CARIBE-010	RIB
C9 - C9X	ISO-6185-3	CARIBE-002	RIB	DL11	ISO-6185-3	CARIBE-024	RIB
C10- C10 X	ISO-6185-3	CARIBE-001	RIB	DL12	ISO-6185-3	CARIBE-023	RIB
L8	ISO-6185-3	CARIBE-013	RIB	DL13	ISO-6185-3	CARIBE-022	RIB
L9	ISO-6185-3	CARIBE-014	RIB	DL15	ISO-6185-3	CARIBE-021	RIB
L10	ISO-6185-3	CARIBE-015	RIB	DL17	ISO-6185-3	CARIBE-027	RIB
L11	ISO-6185-3	CARIBE-025	RIB	DL20-DL20S	ISO-6185-3	CARIBE-026	RIB
C12-T12 C12X-T12X	ISO-6185-3	CARIBE-012	RIB	DL25	ISO-6185-3	CARIBE-029	RIB
C13-T13	ISO-6185-3	CARIBE-011	RIB				

CONFORMITY			
CL-13	ISO-6185-3	CARIBE-020	RIB
CL-14	ISO-6185-3	CARIBE-019	RIB
UB-12 B/SC	ISO-6185-3	CARIBE-023	RIB
UB-13 B/SC	ISO-6185-3	CARIBE-022	RIB
UB-15 B/SC	ISO-6185-3	CARIBE-021	RIB
UB-17 B/SC	ISO-6185-3	CARIBE-027	RIB
UB-19 B/SC	ISO-6185-3	CARIBE-017	RIB
UB-20 B/SC	ISO-6185-3	CARIBE-026	RIB
UB-24 B/SC	ISO-6185-3	CARIBE-028	RIB
C25	ISO-6185-3	CARIBE-004	RIB
C27-I27	ISO-6185-3	CARIBE-005	RIB
C32-I32	ISO-6185-3	CARIBE-006	RIB

•Application of council directive (s) 94/25/EC. / AMENDED 2003 / 44 / EC

•Design category: C

•C inshore: craft designed for voyages in coastal waters,large bays,estuaries,lakes and rivers,where conditions up to and including wind force 6 (beaufort scale) and significant wave heights up to inluding 2 meters (6,56 ft) may be experienced.

•Manufacturer's Name: Caribe Náutica, C.A.

•Manufacturer's Address: 1ra. Calle la industria Edf. Caribe Zona Industrial Palo Verde. Caracas-Venezuela.

•Importer / Dealer Name: _____

•Importer / Dealer Address: _____

international Marine Certification Institute.
Tréves Centre,Rue de Tréves 45,1040 Brussels,Belgium.

•Certifying Body: Phone: +32.2/238-7892. Fax: +32.2/238-7700

Web: www.imci.org



I, the undersigned, hereby declare that the equipment specified above are conforms to the above Directive(s) Standard(s).

Bruno D'Addezio-President-Caribe Náutica, C.A.

LIGHT LINE

UB 24

	L8	L9	L10	L11
O.A. (A)	2,51 mt	2,86 mt	3,10 mt	3,38 mt
LENGTH	8'3"	9'1"	10'3"	11'1"
O.A. (B)	1,64 mt	1,64 mt	1,64 mt	1,70 mt
BEAM	5'5"	5'5"	5'5"	5'7"
MAX ENGINE	8 KW	11 KW	15 KW	15 KW
ENGINE SHAFT	10HP	15HP	20HP	20HP
ENGINE SHAFT	SHORT (15")	SHORT (15")	SHORT (15")	SHORT (15")
MAX LOAD CAPACITY	448 Kg	520 Kg	577 Kg	647 Kg
MAX No. PERSONS	4	4	4	5
APPROX WEIGHT B.	42 Kg	45 Kg	54 Kg	62 Kg
APPROX WEIGHT B.	93 Lbs	105 Lbs	120 Lbs	136 Lbs
tube Ø	0,44	0,44	0,44	0,44

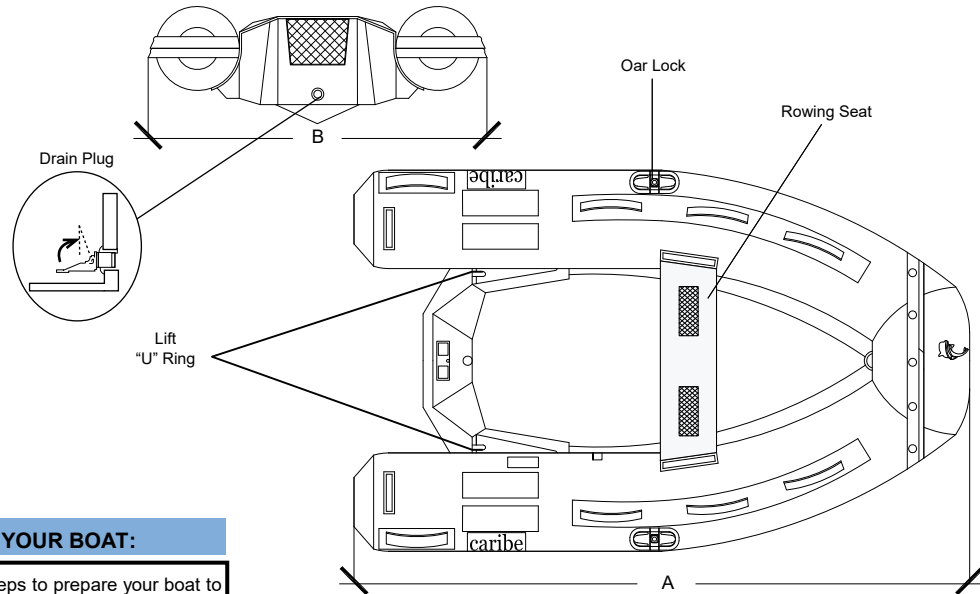

STANDARD ACESORIES

2 OARS • FOOT PUMP • REPAIR KIT
ROWING SEAT • DOCUMENT POCKET

WARNING:

Before launching the Boat, make sure all plugs are secured into the valves

PREPARE YOUR BOAT:

Please follow these steps to prepare your boat to navigate:

- 1) Inflate the tubes (page 7).
- 2) Installation of the oars (page 5).
- 3) Installation of the seat (page 5).
- 4) Placing the drain plug.

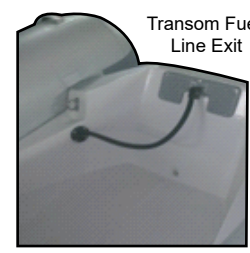

Seat/Console	UB24SC
O.A (A) LENGTH	7,33 mt 24'05"
O.A (B) BEAM	2,73 mt 9'
MAX ENGINE	224 KW 300 HP
ENGINE SHAFT	XL -25"
MAX LOAD CAPACITY	2200 KG 4850 LBS
MAX No. PERSONS	16
APROX WEIGHT B (B)	638 KG 1406 LBS
APROX WEIGHT B (SC)	368 KG 1472 LBS
APROX GAS CAPACITY	300 LTS 79 GAL
tube Ø	0,57

STANDARD ACESORIES

*PADDLE*PUMP *REPAIR KIT

PREPARE YOUR BOAT:

- 1) Inflate the tubes (page 7)
- 2) Placing the drain plug.(this page)

WARNING :

Before launching the boat,make sure that the drainplugs are secured into the valves

DISTRIBUTION UNDER DECK

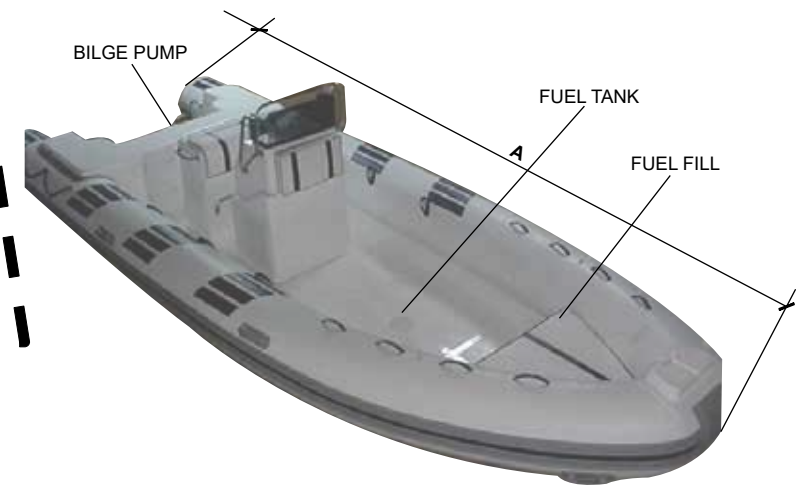
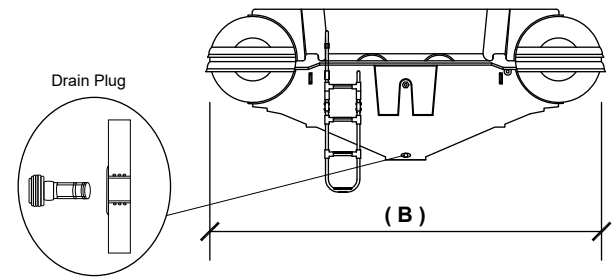
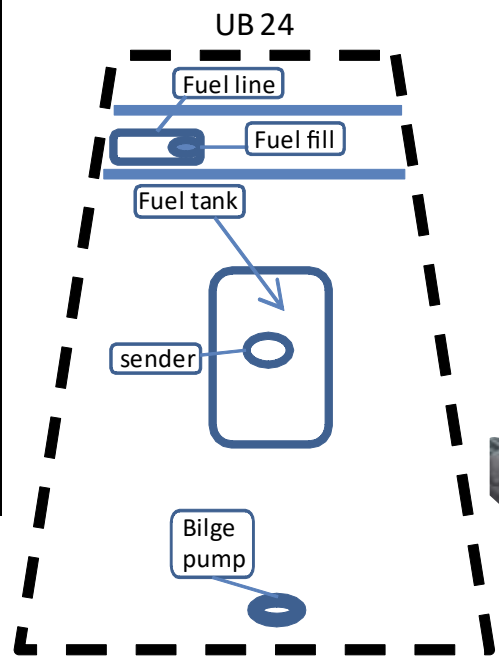

UB 12 - UB 13 - UB 15

DINGHIES LINE

Basic	UB 12B	UB 13B	UB 15B
Seat/Console	UB 12SC	UB 13SC	UB 15SC
O.A (A) LENGTH	3,50 mt 11'48"	4,00 mt 13'3"	4,55 mt 15'
O.A (B) BEAM	1,85 mt 6'07"	1,82 mt 6'	1,97 mt 6'6"
MAX ENGINE	31 KW 40 HP	38 KW 50 HP	52,3 KW 70 HP
ENGINE SHAFT	LONG (20")	LONG (20")	LONG (20")
MAX LOAD CAPACITY	723 KG 1593 LBS	827 KG 1823 LBS	907 KG 2000 LBS
MAX No. PERSONS	5	6	8
APROX WEIGHT B. (B)	165 KG 363 LBS	185 KG 407 LBS	205 KG 451 LBS
APROX WEIGHT B.(SC)	174 KG 383 LBS	200 KG 440 LBS	220 KG 484 LBS
APROX GAS CAPACITY	50 LTS 13 GAL	55 LTS 14 GAL	90 LTS 24 GAL
tube Ø	0,44	0,44	0,49

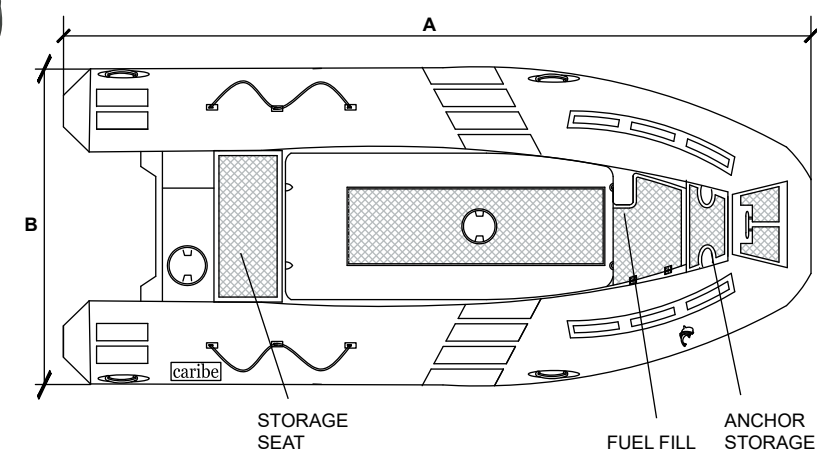
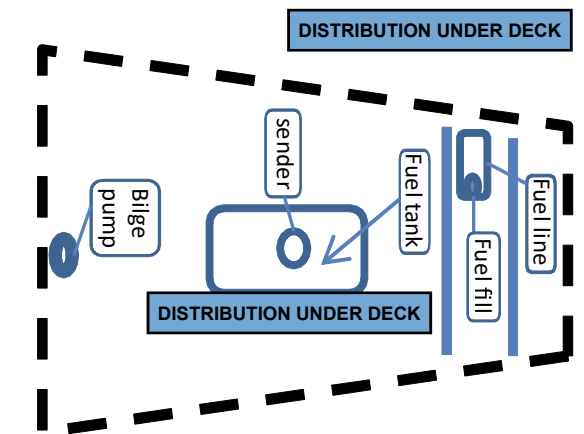
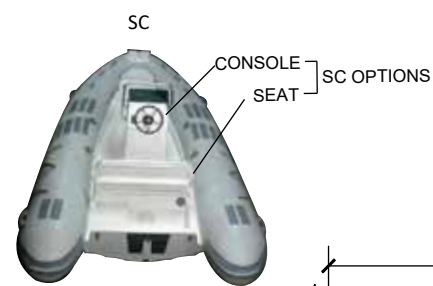
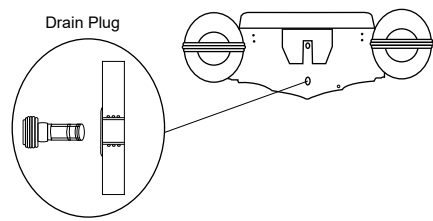

WARNING :
Before launching the boat, make sure that the drain plugs are secured into the valves

STANDARD ACCESORIES
*PADDLE*PUMP *REPAIR KIT

PREPARE YOUR BOAT:
Please follow these steps to prepare your boat to navigate:
1) Inflate the tubes (page 7)
2) Placing the drain plug.(this page)

	C8	C8X	C9	C9X	C10	C10X
O.A. (A) LENGTH	2,51 mt 8'3"	2,51 mt 8'3"	2,86 mt 9'1"	2,86 mt 9'1"	3,10 mt 10'3"	3,10 mt 10'3"
O.A. (B) BEAM	1,62 mt 5'5"	1,62 mt 5'5"	1,63 mt 5'4"	1,63 mt 5'4"	1,63 mt 5'4"	1,63 mt 5'4"
MAX ENGINE	8 KW 10HP	8 KW 10HP	11 KW 15HP	11 KW 15HP	15 KW 20HP	15 KW 20HP
ENGINE SHAFT	SHORT (15")	SHORT (15")	SHORT (15")	SHORT (15")	SHORT (15")	SHORT (15")
MAX LOAD CAPACITY	448 Kg 987 Lbs	448 Kg 987 Lbs	520 Kg 1146 Lbs	520 Kg 1146 Lbs	577 Kg 1272 Lbs	577 Kg 1272 Lbs
MAX No. PERSONS	4	4	4	4	4	4
APPROX WEIGHT B.	55 Kg 121 Lbs	58 Kg 127 Lbs	54 Kg 119 Lbs	60 Kg 132 Lbs	60 Kg 132 Lbs	66 Kg 145 Lbs
TUBE Ø	0,44	0,44	0,44	0,44	0,44	0,44
*C8X-C9X-C10X WITH BOW STORAGE						

STANDARD ACCESORIES
2 OARS • FOOT PUMP • REPAIR KIT
ROWING SEAT • DOCUMENT POCKET

WARNING:
Before launching the Boat, make sure all plugs are secured into the valves

PREPARE YOUR BOAT:
Please follow these steps to prepare your boat to navigate:
1) Inflate the tubes (page 7).
2) Installation of the oars (page 5).
3) Installation of the seat (page 5).
4) Placing the drain plug.
5) Tighten the condensation valve.

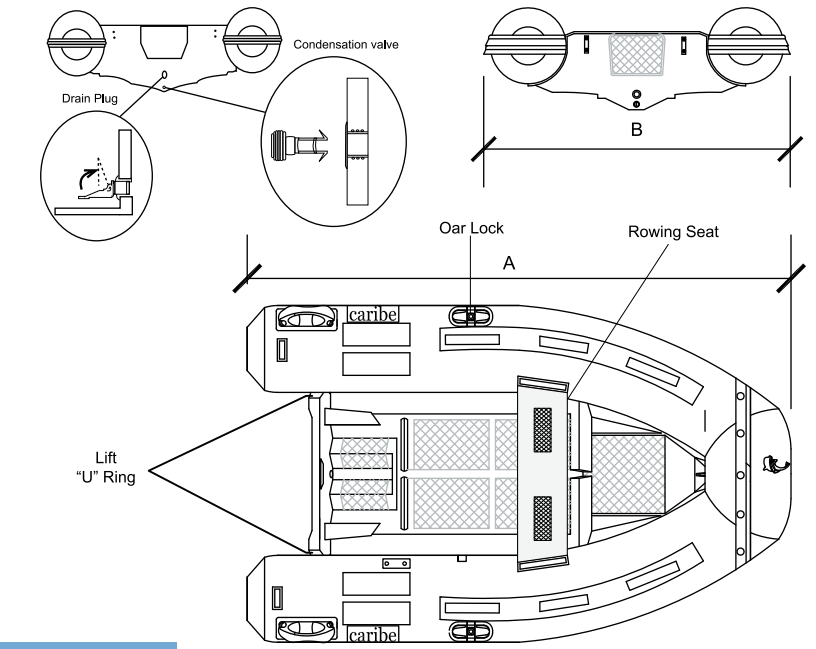

ACCESORIES:

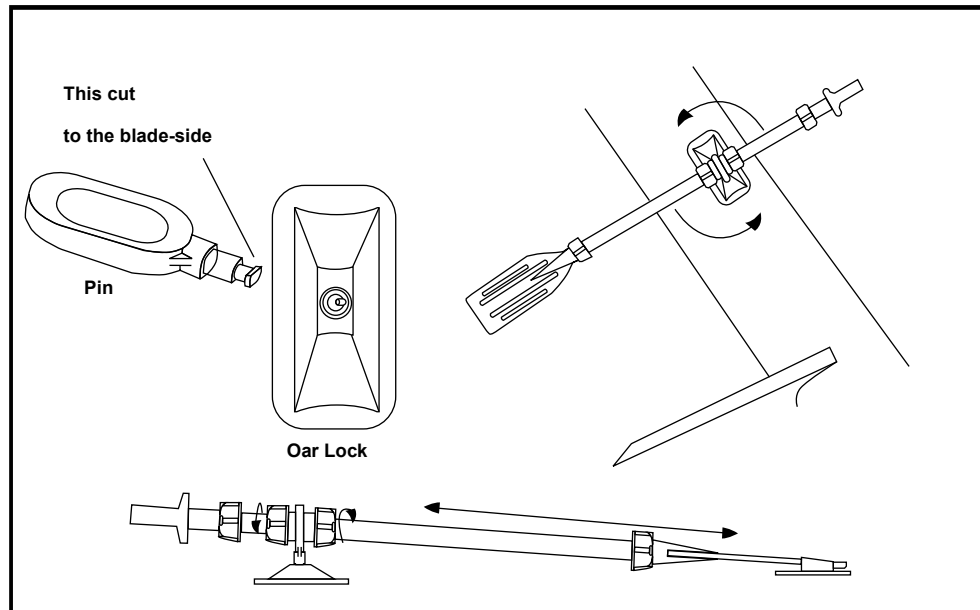
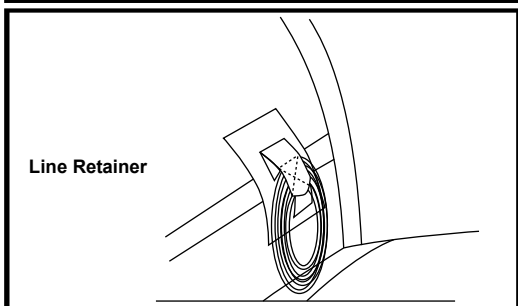
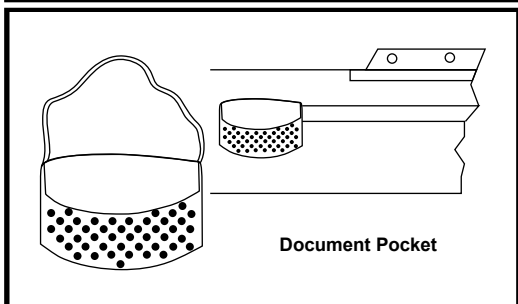
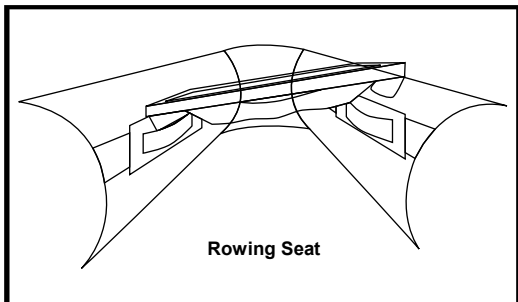

STEPS TO INSTALL THE OARS

- 1) Mount the pin in the oar, making sure that be on the same side of the blade
- 2) With the blade towards the interior of the boat introduce the pin in the oar lock and rotate the oar to the stern side.
- 3) Verify that the pin has hooked on and does not come out of the oar lock.
- 4) Put the paddle of the oar in the blade rest and tighten the telescopic regulator.

UB 17 - UB19 - UB20

Basic	UB 17B	UB 19B	UB 20B
Seat/console	UB 17SC	UB 19SC	UB 20SC
O.A. (A)	5,70 mt	5,85 mt	6,05 mt
LENGTH	17'	19'	20'
O.A. (B)	2,43 mt	2,54 mt	2,43 mt
BEAM	8'	8'3"	8'
MAX ENGINE	112 KW 150HP	112 KW 150HP	131 KW 175HP
ENGINE	LONG (20")	LONG (20")	LONG (20")
MAX LOAD CAPACITY	1385 Kg 3053 Lbs	1600 Kg 3527 Lbs	1492 Kg 3289 Lbs
MAX No. PERSONS	10	10	12
APPROX WEIGHT B. (B)	355 Kg 782 Lbs	465 Kg 1027 Lbs	400 Kg 881 Lbs
APPROX WEIGHT B. (SC)	375 Kg 825 Lbs	485 Kg 1068 Lbs	420 Kg 925 Lbs
APROX FUEL CAPACITY	150 LTS 40 GAL	110 LTS 30 GAL	150 LTS 40 GAL
TUBE Ø	0,61	0,62	0,61

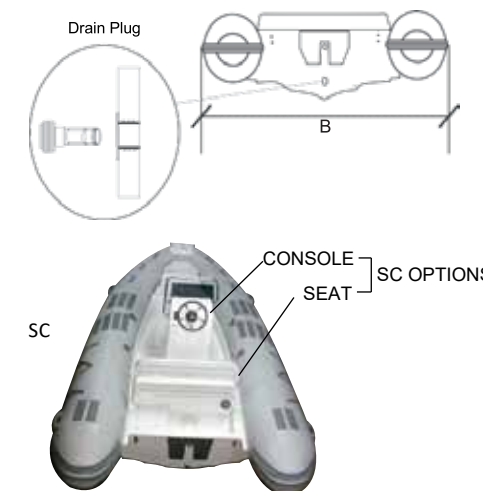

STANDARD ACCESORIES

- PADDLE
- PUMP
- REPAIR KIT

WARNING:

Before launching the boat, make sure that the drain plug is in place

PREPARE YOUR BOAT:

- Please follow these steps to prepare your boat:
- 1) Inflate the tubes (page 6).
 - 2) Placing the drain plug.

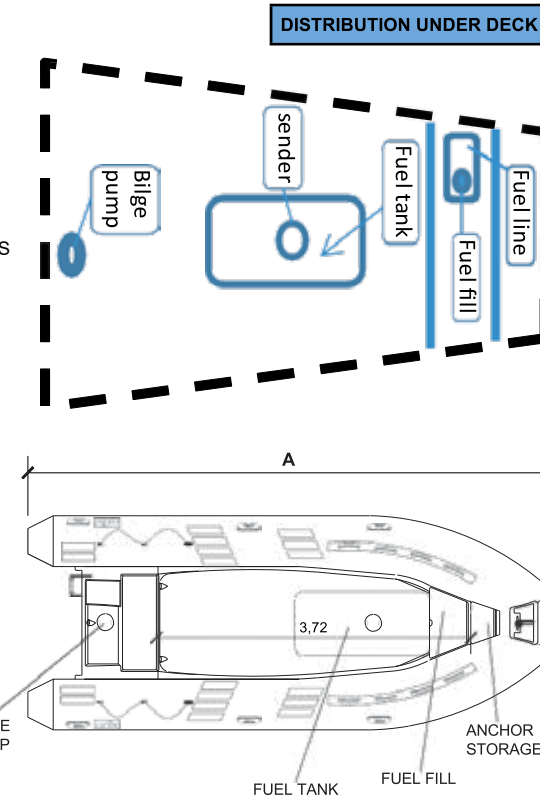

DL25

	DL25
O.A (A) LENGTH	7,62 mt 25'4"
O.A (B) BEAM	2,73 mt 9'1"
MAX ENGINE	225 KW 112 KW 1X300 HP OR 2X150 HP
ENGINE SHAFT	XL-25" (1 ENG.) L-20" (2 ENG.)
MAX LOAD CAPACITY	2300 KG 5066 LBS
MAX No. PERSONS	16
APROX FUEL CAPACITY	400 LTS 106,6 GAL
APROX WATER CAPACITY	50 LTS 13,3 GAL
TUBE Ø	0,57

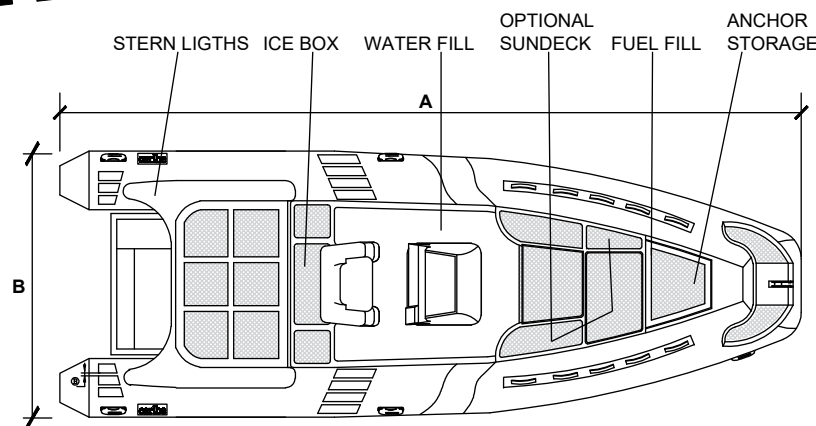
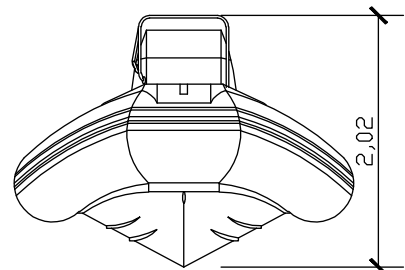
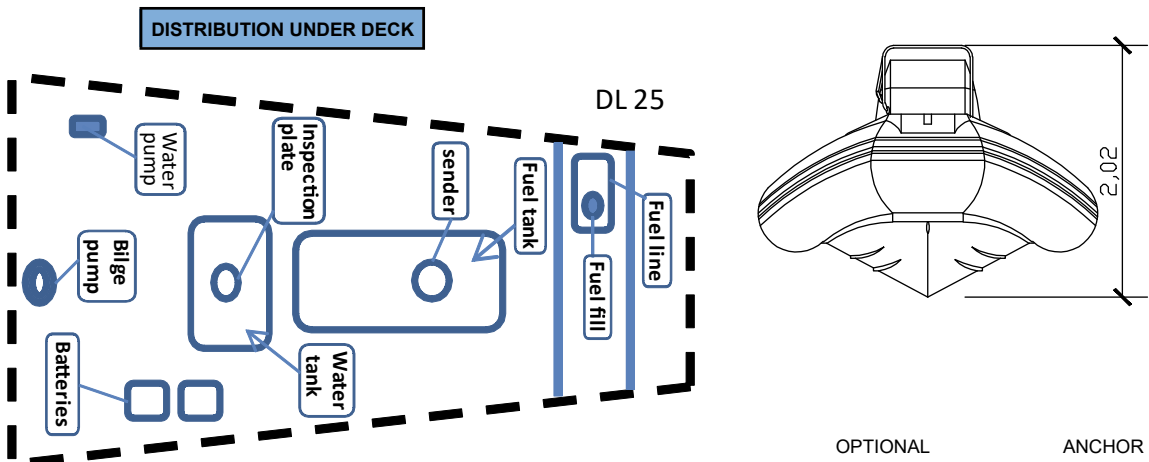

USE AND PERFORMANCE

TRANSOM:

The high of the transom it determines the long of motor shaft that your boat need, see specs of each model.

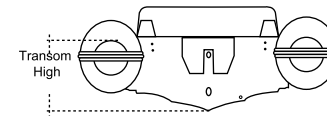

MOTOR:

Use only the indicate shaft. Do not exceed the maximum power.

PLANING:

In order to achieve maximum performance the boat should reach its planing conditions. Planing occurs when the boat assumes in navigation a position parallel to the water surface. If the weight of payload and persons aboard is well distributed, planing should be reached while increasing the speed after the start. It is normal to have a slight lift at bow at the start, to correct move at start, the loads forward.

BOAT DON'T PLANE EASY:

CAUSES:

- The motor shaft is too far from the transom. This can be corrected by positioning the shaft bolt in a hole closer to the transom
- Incorrect distribution of the weights. In this case displace the weights towards the bow.

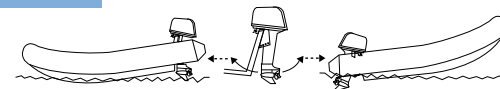

WARNING:

Do not exceed the maximum engine power rating stated on the certification plate attached to your boat.

CAUTION:

Portable tanks must be removed from the boat when fueling.

TOWING-LIFTING:

TOWING:

For towin, use the "U" Ring at the bow. The boat should be towed for short distances and at not more than 4 knots. If you need to tow the boat frequently, we recommend installing two additional tow rings at bow.

WARNING:

- Never tow a bow with people on board
- Use a tow line that is rated at least 4 time the gross weight of the boat being towed.

CAUTION:

The molded rubber handles must never be used for towing.

LIFTING:

4 or 3 rings (at stern and at bow) that could be used to lift the boat. The boat must be lifted in such a way that the lifting lines should work perpendicular with the boat (see fig. 1) and not with horizontal components such as in fig. 2

WARNING:

Do not hoist the boat with people on board.

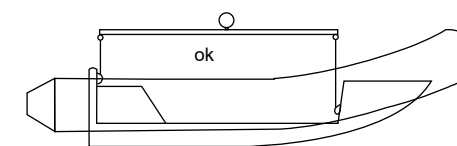

Fig. 1

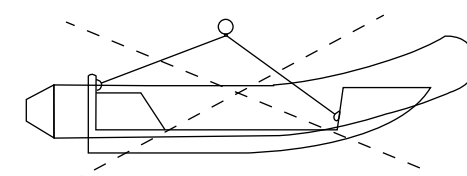
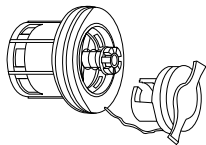

Fig. 2

TO INFLATE THE TUBES:



VALVE:

Remove the cap.

Put the valve in close position. The valve is in close position when the internal poppet is out.

a) Caribe valve: If the poppet is in, just press it.

b) Other valve: If the poppet is in, press and twist it to get it out.

PUMP:

The pump has an adapter at the terminal of the hose, insert the hose with the locking adapter to the valve and turn to lock.



INFLATE:

Inflating sequence: first the rear chambers, then the one at bow. Replace the cap on the valves.

PRESSURE:

Working pressure: 0.2 bar (The pressure gauge is not included with the boat).

A practical method to estimate the pressure of the tubes:

If you can not depress the tube more than 1 cm (1/2") with the pressure of your finger.

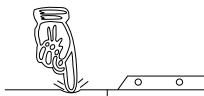

DEFLATION:

To deflate the air chamber, open the valve by pressing and twisting the poppet or just by pressing it according to the model of the valve.

WARNING:

Never use a high pressure pump to inflate your boat because it could damage the valve or the tube.

MAINTENANCE:

GENERAL:

To maintain the good appearance of your Caribe boat, we recommend washing it periodically with a mild soap and water and drying it with a soft cloth.

INFLATABLE PARTS:

Some persistent stains can be removed by a stain remover product that should not contain solvents.

FIBERGLASS PARTS:

In addition to washing with soap and water, we recommend protecting them with a special wax for gel-coat at least twice a year.

AIR VALVES:

Periodically check that there is no dirt or sand that could obstruct a total seal.

CONDENSATION VALVE:

Periodically check to verify that the condensation valve has the "O" ring on and that there is no dirt or sand in the threads of the valve.

WARNING:

Use as few cleaning agents as possible, do not discharge waste agents into the water.

CAUTION:

Do not cover the boat with a canvas until completely dry, as this could damage the fabric of the tubes due to mildew and water stains.

	DL17	DL20	DL20S
O.A. (A) LENGTH	5,10 mt 16'9"	6,05 mt 20'	6,05 mt 20'
O.A. (B) BEAM	2,48 mt 8'2"	2,48 m 8'	2,48 m 8'
MAX ENGINE	112 KW 150 HP	131 KW 175 HP	31 KW 175 HP
ENGINE SHAFT	LONG (20")	LONG (20")	LONG (20")
MAX LOAD CAPACITY	1385 Kg 3053 Lbs	1492 Kg 3289 Lbs	1492 Kg 3289 Lbs
MAX No. PERSONS	10	12	12
APPROX WEIGHT B.	420 Kg 926 Lbs	500 Kg 1100 Lb	600 Kg 1322 Lb
APROX FUEL CAPACITY	150 LTS 40 GAL	150 LTS 40 GAL	150 LTS 40 GAL
APROX WATER CAPACITY	40 LTS 10,6 GAL	40 LTS 10,6 GAL	40 LTS 10,6 GAL
TUBE Ø	0,61	0,61	0,61

STANDARD ACCESSORIES

• PADDLE • PUMP • REPAIR KIT

WARNING:

Before launching the Boat, make sure that the drain plug is in place.

DL 17 - DL 20 - DL 20S

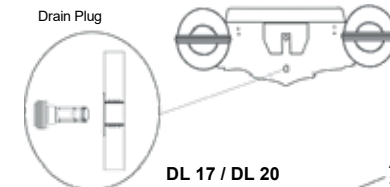
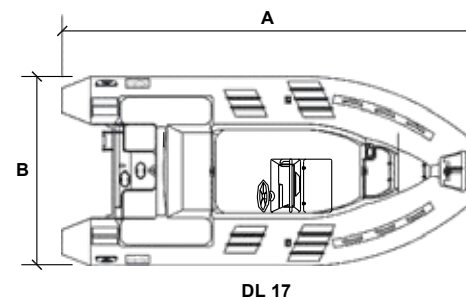
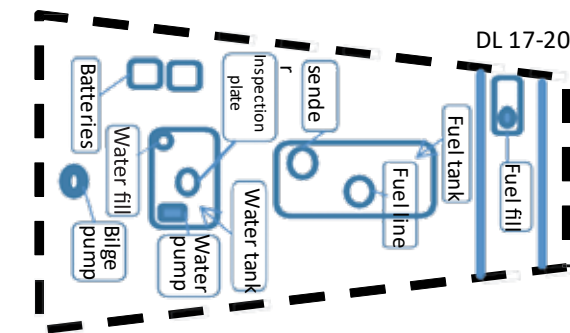

DL 17 / DL 20

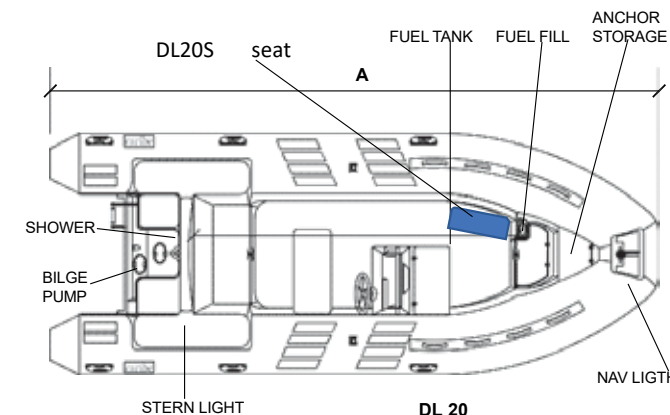
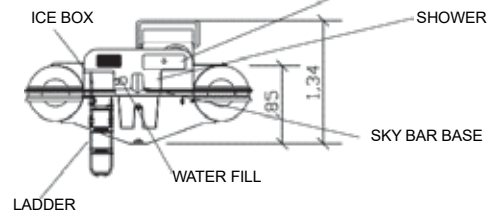

PREPARE YOUR BOAT:

Please follow these steps to prepare your boat to navigate:

- 1) Inflate the tubes (page 7).
- 2) Placing the drain plug (this page).

DL LINE

	DL11	DL12	DL13	DL15
O.A. (A) LENGTH	3,37 mt 11'1"	3,70 mt 12'2"	4,00 mt 13'3"	4,60 mt 15'2"
O.A. (B) BEAM	1,73 mt 5'7"	1,77 mt 5'9"	1,82 mt 6'	1,96 mt 6'7"
MAX ENGINE	31 KW 40HP	38 KW 50HP	53 KW 70HP	68 KW 90HP
ENGINE SHAFT	LONG (20")	LONG (20")	LONG (20")	LONG (20")
MAX LOAD CAPACITY	562 Kg 1238 Lbs	723 Kg 1593 Lbs	827 Kg 1823 Lbs	907 Kg 1999 Lbs
MAX No. PERSONS	5	5	6	8
APPROX WEIGHT B.	155 Kg 341 Lbs	171 Kg 378 Lbs	288 Kg 634 Lbs	250 Kg 550 Lbs
APROX FUEL CAPACITY	50 LTS 13,3 GAL	50 LTS 13,3 GAL	60 LTS 16 GAL	90 LTS 24 GAL
TUBE O	0,44	0,44	0,49	0,49
APROX WATER CAPACITY	25 LTS 6,6 GAL	25 LTS 6,6 GAL	35 LTS 9,3 GAL	40 LTS 10,6 GAL

STANDARD ACCESORIES

• PADDLE • PUMP • REPAIR KIT

PREPARE YOUR BOAT:

Please follow these steps to prepare your boat to navigate:

- 1) Inflate the tubes (page 7).
- 2) Placing the drain plug (this page).

WARNING:

Before launching the boat, make sure that the drain plug is in place

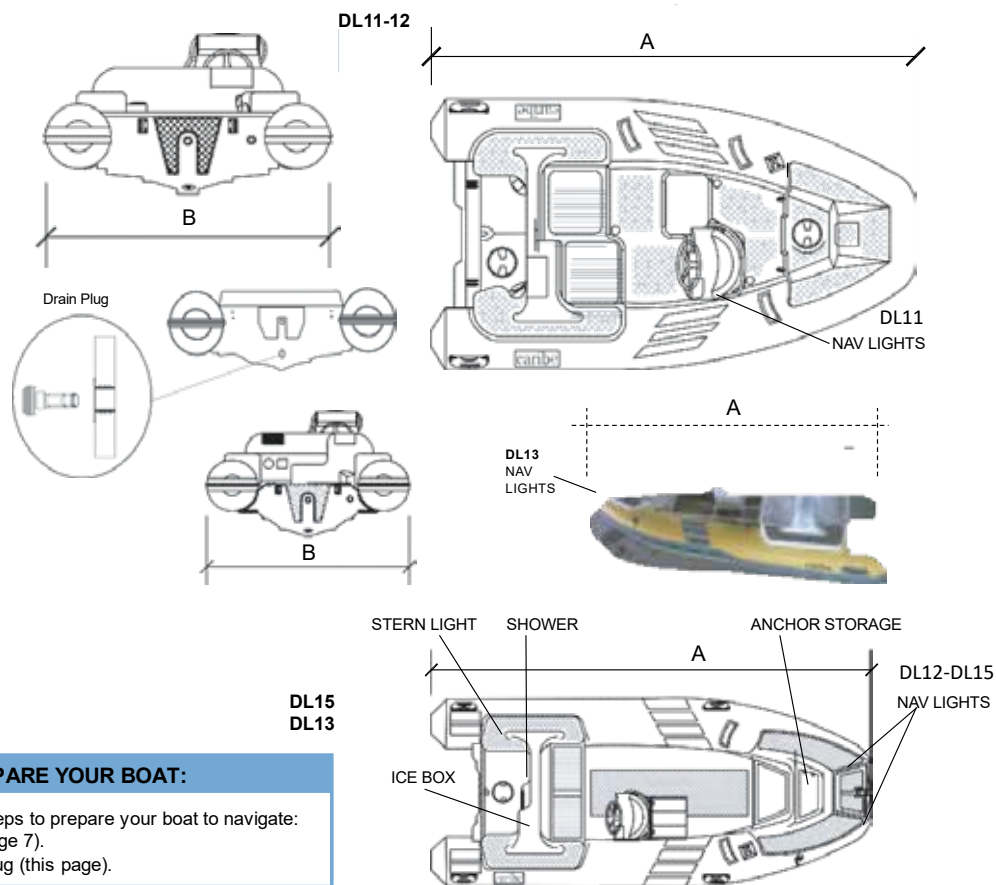

RUNABOUT LINE

	C12/T12	C12X-T12X	C13/T13	C14/T14
O.A (A) LENGTH	3,50 mt 11'6"	3,70 mt 12'1"	4,00 mt 13'3"	4,20 mt 14'
O.A (B) BEAM	1,67 mt 5'6"	1,87 mt 6'1"	1,82 mt 6"	2,00 mt 6'6"
MAX ENGINE	22 KW 30 HP	22 KW 30HP	36 KW 50HP	36 KW 50HP
ENGINE SHAFT	SHORT 15"	Short 15"	LONG 20"	LONG 20"
MAX LOAD CAPACITY	658 KG 1450 LBS	658 KG 1450 LBS	940 KG 2072 LBS	1280 KG 2667 LBS
MAX No. PERSONS	5	5	6	8
APROX WEIGHT B.	85 KG 187 LBS	145 KG 388 LBS	125 KG 275 LBS	130 KG 286 LBS
TUBE O	0,47	0,47	0,47	0,51

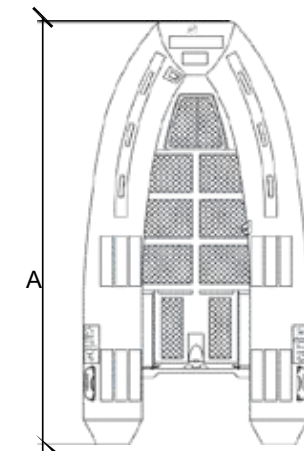
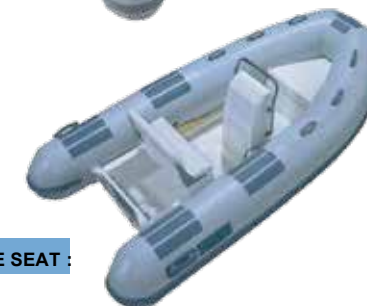
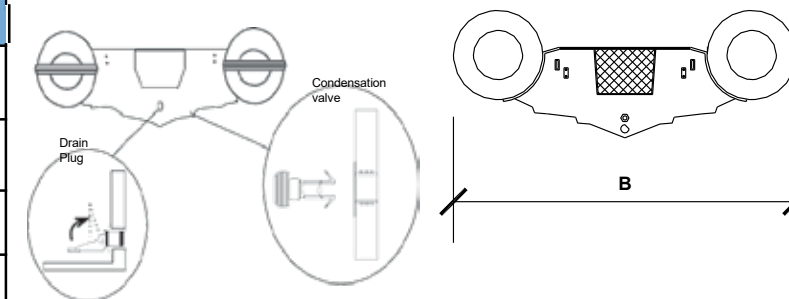

WARNING:

Before launching the Boat, make sure all plugs are secured into the valves

STANDARD ACCESORIES

2 PADDLE * PUMP * REPAIR KIT * SEAT

PREPARE YOUR BOAT:

Please follow these steps to prepare your boat to navigate :

- 1) Inflate the tubes (page 7)
- 2) Placing the drain plug (this page)
- 3) Tighten the condensation valve (this page)

T12
T15
CONSOLE SEAT :

CL LINE

INTERNAL DISTRIBUTION

	CL13	CL14
O.A. (A)	4,00 mt	4,30 mt
LENGTH	13'3"	14'1"
O.A. (B)	1,90 mt	1,90 mt
BEAM	6'3"	6'3"
MAX ENGINE	40 KW	52 KW
ENGINE	50HP	70HP
ENGINE SHAFT	LONG	LONG
MAX LOAD CAPACITY	940 Kg	1040 Kg
	2072 Lbs	2292 Lbs
MAX No. PERSONS	6	6
APPROX WEIGHT B.	212 Kg	229 Kg
	468 Lbs	506 Lbs
APPROX FUEL CAPACITY	60 LTS	70 LTS
	16 GAL	18,6 GAL
TUBE Ø	0,51	0,51
APPROX WATER CAPACITY	20 LTS	20 LTS
	5,3 GAL	5,3 GAL

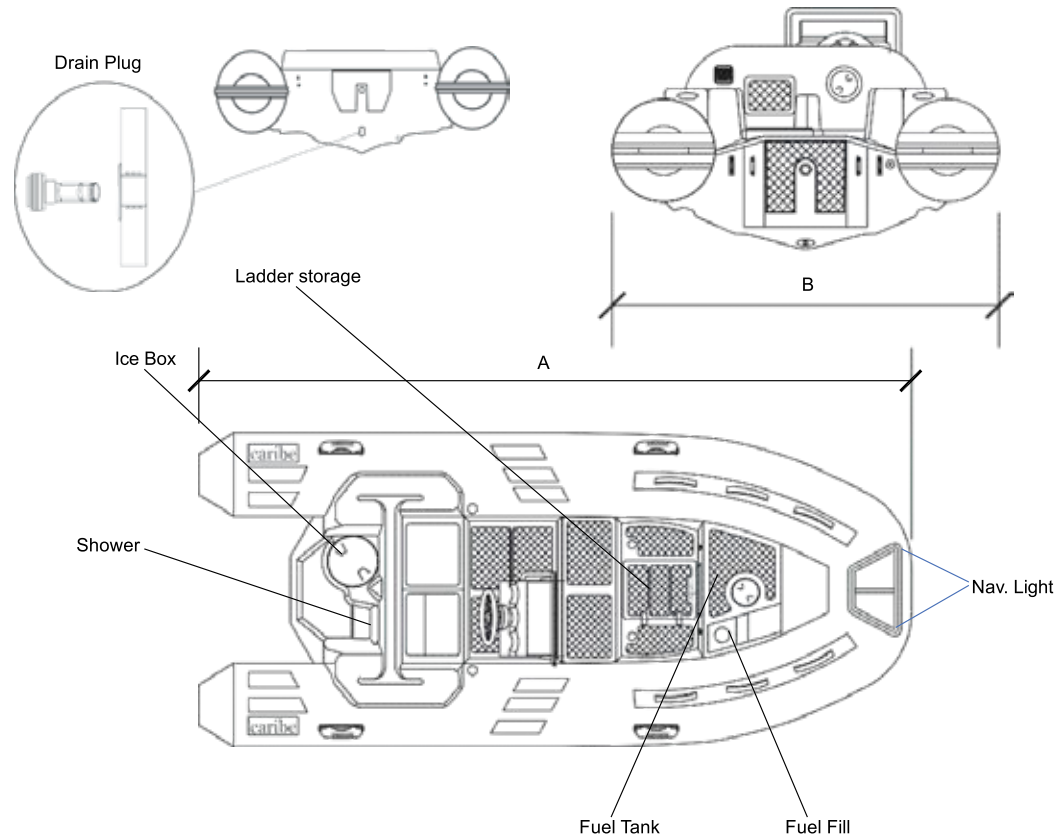

STANDARD ACCESSORIES

- PADDLE
- PUMP
- REPAIR KIT

WARNING:

Before launching the boat, make sure that the drainplugs are secured into the valves.

PREPARE YOUR BOAT:

- Please follow these steps to prepare your boat to navigate:
- 1) Inflate the tubes (page 7).
 - 2) Placing the drain plug (this page).

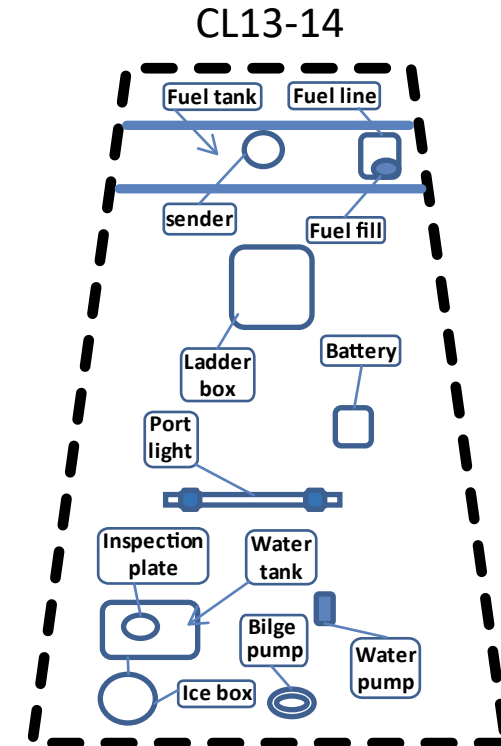
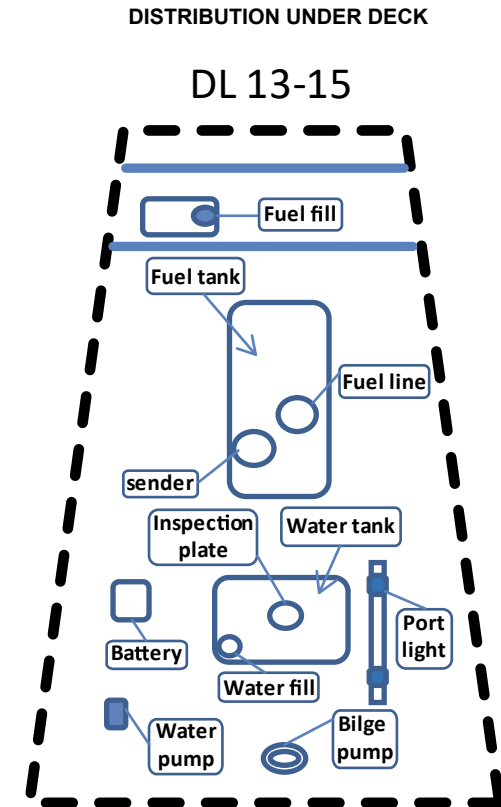
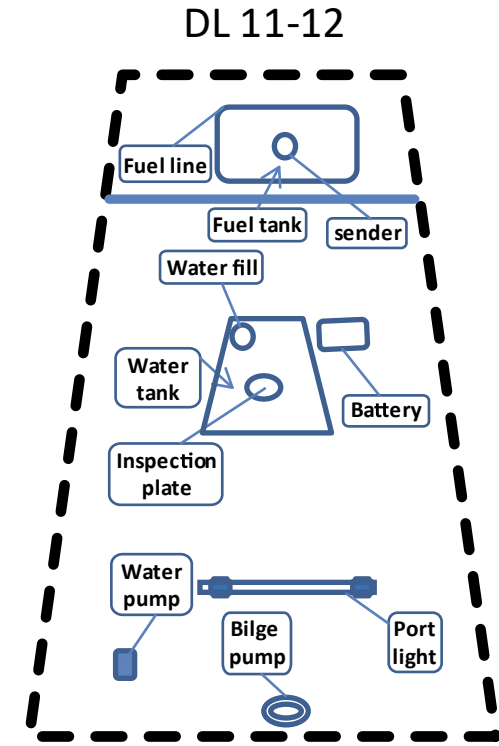

* See under deck distribution in pag 10.